

T-7580

5/16" PUNCH/FLANGE



OILING INSTRUCTIONS:
OIL AFTER EACH USE
WITH A FEW DROPS OF
AIRTOOL OIL THROUGH
THE AIR INLET. RUN FOR
1 SECOND TO COAT ALL
INTERNAL PARTS

MAINTAIN FLUID LEVEL (30
WT NON DETERGENT OIL)
THROUGH PLUG #6

THIS TOOL IS AN AIR OVER
HYDRALIC PUNCH/FLANGE.

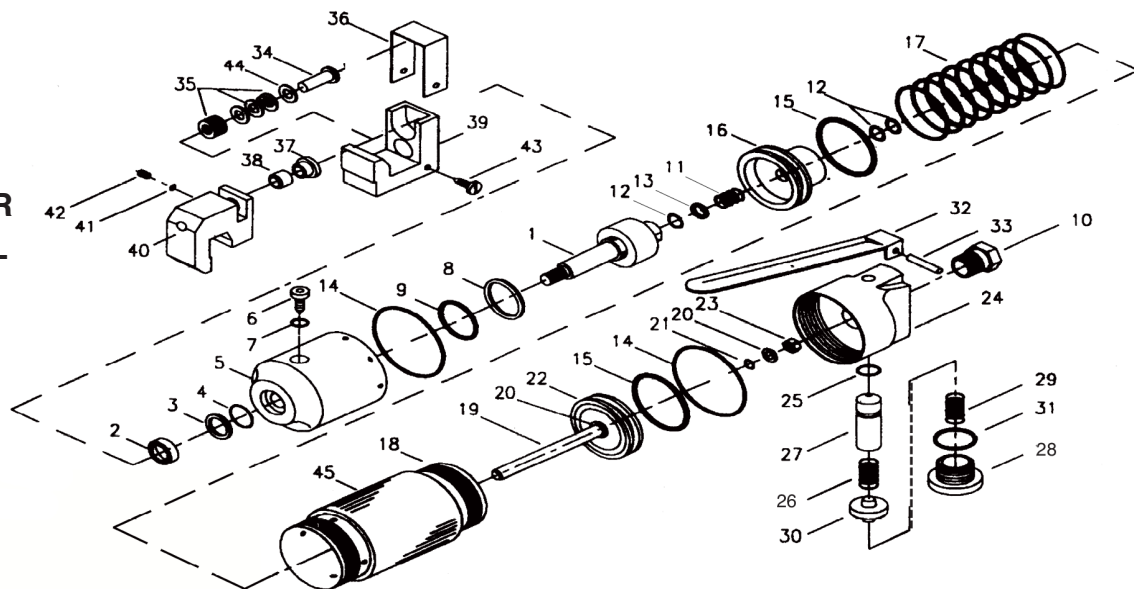

USE 90 PSI MAXIMUM

REF #	PART #	DESCRIPTION	QTY	REF #	PART #	DESCRIPTION	QTY
1	758001N	PISTON	1	24	758024N	AIR VALVE BODY	1
2	758002N	PACKING	1	25	758025N	O-RING	1
3	758003N	BACK-UP RING	1	26	758026N	SPRING	1
4	758004N	O-RING	1	27	758027N	AIR VALVE	1
5	758005N	CYLINDER	1	28	758028N	PLUG	1
6	758006N	OIL PLUG	1	29	758029N	SPRING	1
7	758007N	O-RING	1	30	758030N	VALVE COVER	1
8	758008N	BACK-UP RING	1	31	758031N	O-RING	1
9	758009N	O-RING	1	32	758032N	LEVER	1
10	758010N	AIR INLET	1	33	758033N	PIN	1
11	758011N	SPRING	1	34	758034N	PUNCH	1
12	758012N	O-RING	3	35	758035N	SPRING WASHER	12
13	758013N	BACK-UP RING	1	36	758036N	COVER	1
14	758014N	O-RING	2	37	758037N	GUIDE SLEEVE	1
15	758015N	O-RING	2	38	758038N	PUNCHING DIE	1
16	758016N	PISTON	1	39	758039N	ANVIL BED	1
17	758017N	SPRING	1	40	758040N	PUNCHIND DIE BED	1
18	758018N	CYLINDER	1	41	758041N	PACKING	1
19	758019N	PISTON ROD	1	42	758042N	SCREW	1
20	758020N	WASHER	2	43	758043N	SCREW	2
21	758021N	O-RING	1	44	758044N	WASHER	1
22	758022N	PISTON	1	45	758045N	PLASTIC COVER	1
23	758023N	LOCK NUT	1				